

STYLE AND DIMENTION OF REEL (FREE)

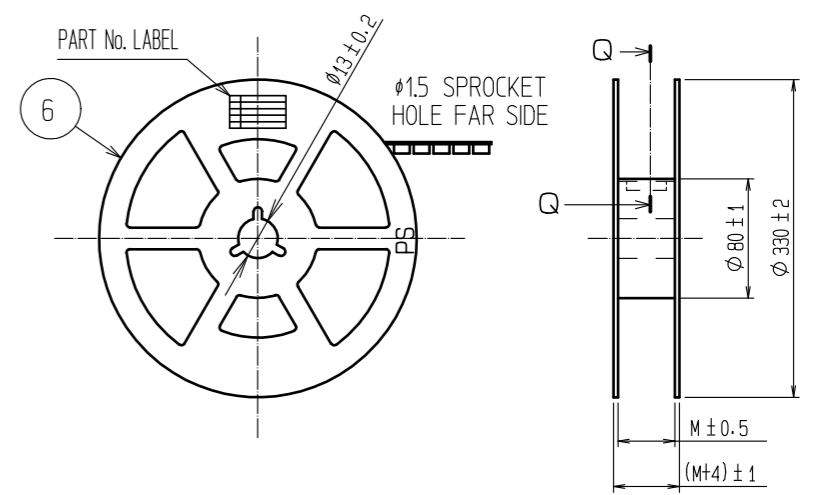

Q-Q (FREE)

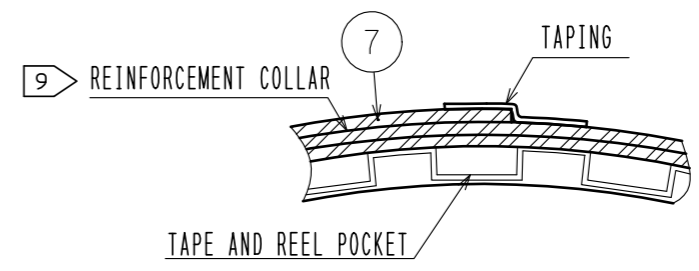

SUPPLIER
 QUANTITY
 PART No.
 CODE No.
 DATE OF MANUFACTURED

DETAIL OF PART No. LABEL

生産月日	年 月 日
図番	CL537-****-*-86
品名	DF12B(3.0)-*DS-0.5V(86)
納入数量	1000K \square
納入者	ヒロセ電機(株)

CODE No.	CONTACT	H	J	K	L	M
CL537-0651-6-86	10	16	-	7.5	0.30	17.5
CL537-0916-9-86	14	16	-	7.5	0.30	17.5
CL537-0653-1-86	20	16	-	7.5	0.38	17.5
CL537-0655-7-86	30	24	-	11.5	0.38	25.5
CL537-0662-2-86	32	24	-	11.5	0.30	25.5
CL537-0656-0-86	36	24	-	11.5	0.38	25.5
CL537-0657-2-86	40	24	-	11.5	0.38	25.5
CL537-0659-8-86	50	24	-	11.5	0.38	25.5
CL537-0661-0-86	60	32	28.4	14.2	0.38	33.5
CL537-0663-5-86	80	44	40.4	20.2	0.38	45.5

- NOTES 4 1 REEL 1000 CONNECTORS.
 5 AT THE BEGINNING OF THE REEL, 30 COMPONENTS SHALL BE EMPTY.
 AT THE END OF THE REEL, 20 COMPONENTS SHALL BE EMPTY.
 6 WHEN THE TAPE WIDTH IS 32 mm OR 44 mm, SPROCKET HOLES SHALL BE SET ON BOTH SIDE OF REEL AS SHOWN ON THIS DRAWING.
 7 PEEL FORCE REFERS TO JIS C 0806. (IEC 60286-3)
 8 THE REEL IS PACKED WITH A POLYETHYLENE MATERIAL, TOGETHER WITH A DRYING AGENT.
 9 AFTER PACKING, ROLL 2 METERS OF THE REINFORCEMENT COLLAR TO OUTER CIRCUMFERE OF TAPE AND REEL POCKET, AND TAPE DOWN AT THE END THE COLLAR.

HRS	DRAWING NO.	EDC3-160764-77
	PART NO.	DF12B(3.0)-*DS-0.5V(86)
	CODE NO.	CL537
		\triangle 2/2